

HOW TO MEET THE BUILDING REGULATIONS FOR WALES – APPROVED DOCUMENT F (2022)

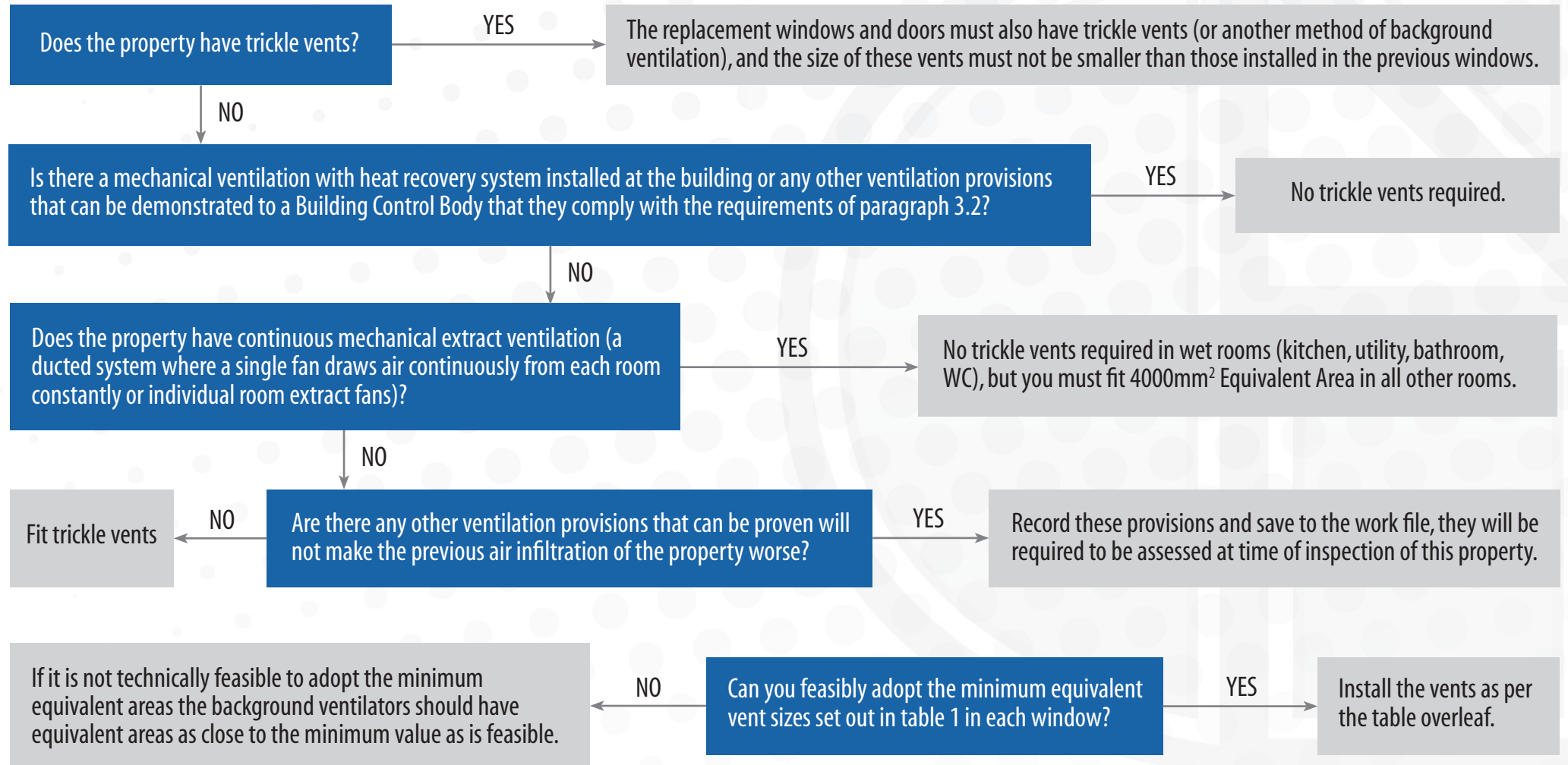

WHAT SIZE TRICKLE VENTS SHOULD I SPECIFY AND FIT?

Room	Minimum equivalent area of background ventilators for dwellings with multiple floors
Habitable rooms	8000mm ²
Kitchen	8000mm ²
Bathroom	4000mm ²

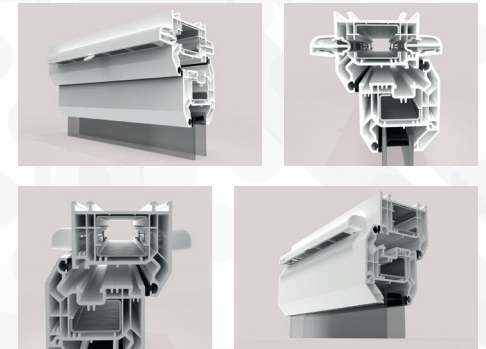

Are there any exemptions?

There are certain exemptions that can be considered. These are listed in clause 0.4 of the Approved Document and are for Listed Buildings and conservation areas and other historic buildings.

Are there any other considerations I should take into account?

Section 2 sets out the provisions for minimising the ingress of external pollutants.

Clause 2.3 states 'Where urban traffic is a source of pollution, the air intakes for dwellings next to busy urban roads should be both of the following.

- a. As high as possible
- b. Located on the less polluted side of the building. Mechanical ventilation may be the most practical way of achieving the requirement'

www.glazpart.com/building-regulations-wales